

GMS

Thermal Products Ltd

www.gmsthermal.co.uk



PLATE HEAT EXCHANGERS

GMS THERMAFLEX PHE'S

Gasketed plate heat exchangers offer a highly effective method of transferring heat from one fluid to another. They are made by compressing a number of gasketed, corrugated plates together in a frame, so that the gaskets give a good seal. The corrugations touch where they cross, support the plates, resisting high working pressures and enhancing heat transfer.



Thermaflex G PHE's - Constructional Details

Plates: The heat transfer plates are pressed from thin material (typically 0.5mm) into a corrugated form with an indented groove for the gasket.

Plate Materials:-

- Stainless steels (AISI 304 or AISI 316) (for most applications)
- Titanium (for sea-water or other high chloride applications)
- Other materials available to special order

Gaskets: Gaskets are available in a variety of compounds:-

- Nitrile - for general applications (including oils)
- EPDM(S) - For water (including potable water)
- EPDM(P) - For higher temperature water and steam

Connections: Connections will generally be of the same material as the plates. However, in some applications carbon steel will be offered if technically suitable and more economical. For some larger units with low fluid velocities connections made from the same material as the gaskets may be offered.

Connection velocities can be relatively high in plate heat exchangers and care should be taken when sizing pipe-work to the connections - you may need a pipe size greater than the connection size.

High heat transfer rates are achieved by:

- Counter-flow operation - passing the fluids in opposite directions through adjacent channels between the plates.
- High heat transfer coefficients - the corrugations cause high turbulence
- Low thermal resistance - Use of corrosion resistant materials (eg stainless steels, titanium etc) combined with the inherent strength of the corrugated plates mean that only relatively thin plates are needed.
- Efficient use of heat transfer surfaces - almost all the plate surface is involved in heat transfer - minimising cost.

Other advantages

- Design flexibility - two types of plates in each size can be combined in six different ways to give the optimum heat transfer and pressure drop characteristics.
- Designed for the job - test-proven computer programs calculate the optimum configuration for each duty
- Space saving - compared to shell and tube units
- Close temperatures? - PHE's can achieve good heat transfer rates even when the temperature difference between the two fluids is small
- Easily modified - more plates can be added to increase duty
- Easily maintained - dismantling and reassembly are simple
- Resistant to scaling and fouling - due to the high level of turbulence
- Fluids don't mix if gaskets leak - because of a double seal (with air hole to atmosphere) around the ports between plates, any gasket leak goes to atmosphere (where it is easily detected) and doesn't mix with the other fluid.

Applications

PHE's are suitable for most heat transfer applications involving fluids at temperatures up to 150°C and pressures up to 16 BarG. Operating temperature is limited by the gaskets. This excludes use of steam above 3.7 BarG.

The ability to cope with close temperatures makes PHE's an excellent choice for heat recovery applications e.g. in industrial processes, laundries, swimming pools, solar heating systems etc. It also makes them ideal for keeping two systems hydraulically separate. Their thermal efficiency often makes them cost effective against shell and tube heat exchangers in many conventional applications such as in building services.

We would be pleased to hear about your particular application. GMS Thermal Products Ltd. manufacture and supply many kinds of heat exchanger and can advise on which type is best suited to it.

WATER HEATING MADE EASY

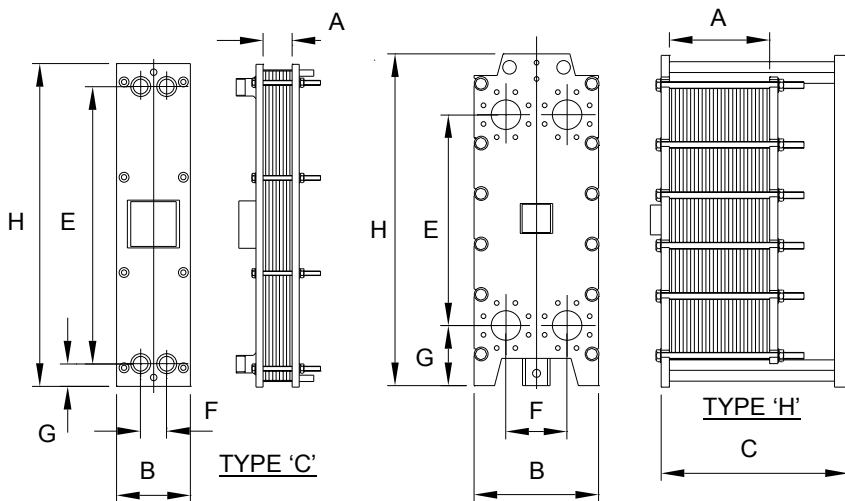

For dimensions 'A' & 'C' and weights, please refer to the computer selection sheet

IMPORTANT

The plate heat exchanger has 4 connections as standard and should be installed with adequate space on both sides for service work.

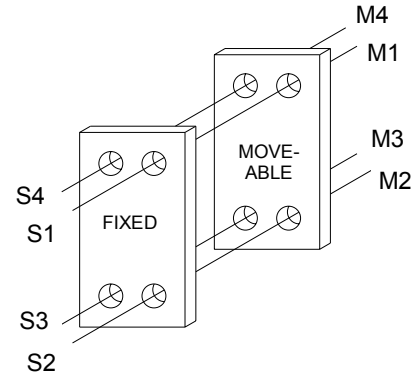

Unit Size	Connections: Screwed BSP / Flanged PN16	Maximum Flowrate m ³ /Hr *	Maximum Heating Surface m ²	Dimensions (mm)				
				H	B	E	F	G
M4	½" BSP	4	0.36	188	72	154	40	17
M10	1" BSP	12	1.92	287	115	243	72	22
GC-12 C	1" BSP	12	3.2	496	165	357	60	70
GC-28 C	1" BSP	12	10.4	808	160	675	65	67
GC-30 C	1½" BSP	30	17	693	250	555	100	90
GC-50 C	2" BSP	50	21	840	320	592	135	140
GC-26 H	DN100 PN16	200	99	1265	460	779	226	220
GC-51 H	DN150 PN16	450	250	1730	630	1143	300	300
GC-60 H	DN200 PN16	800	280	1700	825	910	420	350
GX-7 C	1" BSP	12	7	745	160	640	60	53
GL-13 C	2" BSP	50	19	840	320	592	135	140
GL-16 C	2" BSP	50	29	1070	320	822	135	140
GX-26 H	DN100 PN16	200	120	1265	460	779	226	220
GX-42 H	DN100 PN16	200	200	1675	460	1188	226	220
GX-51 H	DN150 PN16	450	250	1730	630	1143	300	300
GX-37 H	DN150 PN16	450	170	1430	626	840	285	300
GX-64 H	DN150 PN16	450	295	1910	626	1320	285	300
GX-91 H	DN150 PN16	450	420	2390	626	1800	285	300
GX-118 H	DN150 PN16	450	540	2870	626	2280	285	300
GX-60 H	DN200 PN16	800	280	1700	825	910	420	350
GX-100 H	DN200 PN16	800	510	2280	825	1490	420	350
GX-140 H	DN200 PN16	800	580	2860	825	2070	420	350
GX-180 H	DN200 PN16	800	750	3440	825	2650	420	350
GX-85 H	DN300 PN16	1800	460	1985	1060	1140	570	360
GX-145 H	DN300 PN16	1800	750	2565	1060	1720	570	360
GX-205 H	DN300 PN16	1800	840	3145	1060	2300	570	360
GX-265 H	DN300 PN16	1800	1080	3725	1060	2880	570	360
GX-325 H	DN300 PN16	1800	990	4305	1060	3460	570	360

* - Maximum flow applies to suitable plate configurations only

Please note all information shown within this leaflet is subject to change without prior notice.

© GMS Thermal Products 2004
Issue 1, January 2004

GMS THERMAFLEX BHE'S

Brazed plate heat exchangers offer a highly effective method of transferring heat from one fluid to another.

A typical brazed heat exchanger consists of a plate pack fitted between front and rear coverplates. Standard units have a maximum working pressure of up to 31 BarG at a temperature of 225°C.



With a maximum flowrate of up to 200 m³/Hour, most duties will be covered. The majority of our brazed heat exchangers are a stock item. The standard unit is manufactured from stainless steel grade AISI 316 and is brazed with pure copper. Although these units are classed as standard, there is a large range of units with different connection sizes and orientations etc, which ensures we can supply a unit for your requirements.

Connections Available

- Externally threaded connections (Standard) screwed BSP or NPT connections
- Internally threaded connections screwed BSP or NPT connections
- 'Rotalock' connections
- Soldered connections
- Victualic connections
- Welded connections
- Flanged connections (DN50 and DN100)
- SAE flanges
- SAE O-ring connections

Benefits of Brazed Heat Exchangers:

- Extremely compact
- Maximum material efficiency as all the exchanger plate material is effective
- System costs are reduced with a better heat transfer coefficient
- Higher working pressures than gasketed plate heat exchangers and shell & tube exchangers
- Self cleaning

BHE Construction

A typical BHE consists of a plate package between front and rear coverplates as shown. There are numerous variables available including:

- Plate size
- Number of plates
- Plate patterns
- Heat transfer plate materials
- Coverplate materials
- Braze material
- Connections

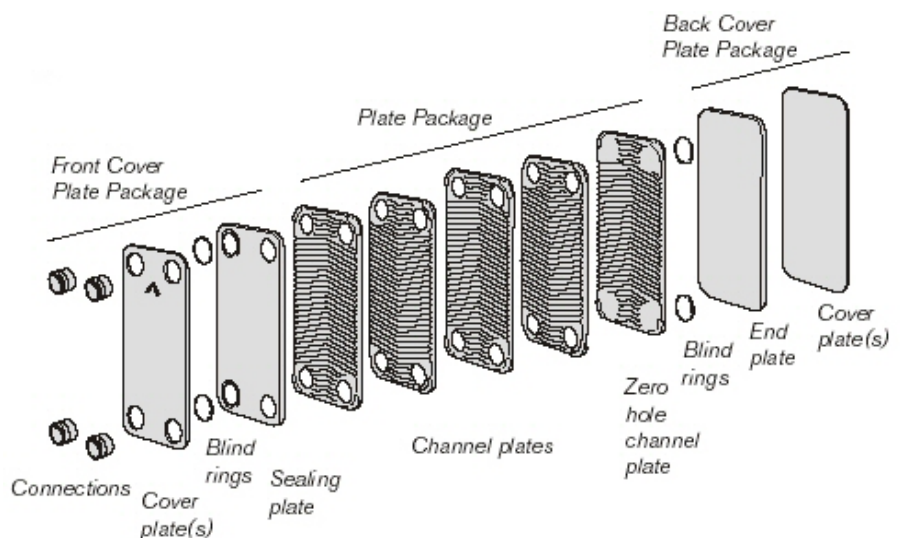

WATER HEATING MADE EASY

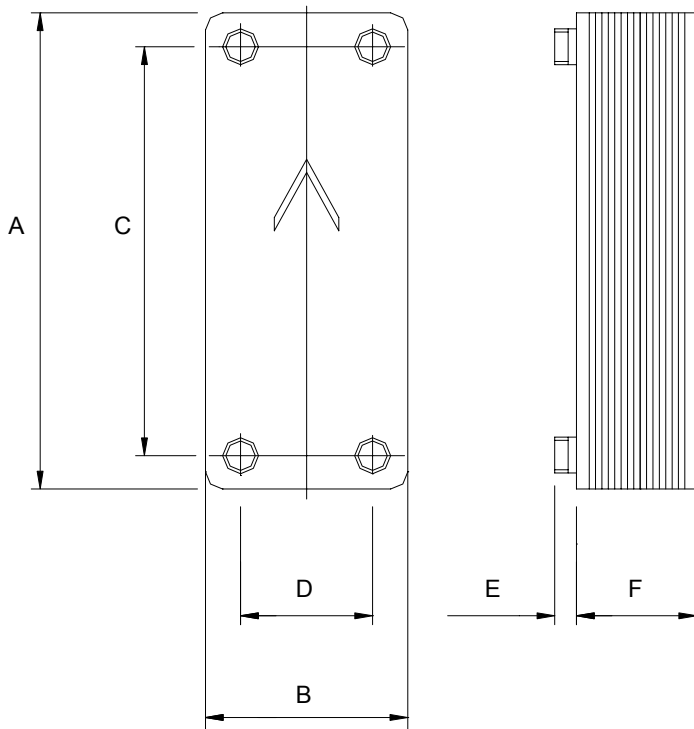

Standard Materials

Plates & Connections: AISI 316 Stainless Steel AISI 316
 Brazing Material: Copper (99.9%) (Nickel based for sizes B25 to B27)

Operating Conditions

Maximum Pressure: 31 BarG
 Maximum Temperature: 185°C
 Minimum Temperature: -195°C

Unit Ref	Dimensions (mm)					Max. No. Plates	Area/Plate m ²	Volume/Channel m ³	Maximum Flowrate m ³ /Hr	Connection Size	E mm	Weight Empty kg
	A	B	C	D	F							
B5	187	72	154	40	9 + 2.3 x np	60	0.012	0.024	4	½" or ¾"	20	0.6 + 0.044 x np
B8	310	72	278	40	9 + 2.3 x np	60	0.023	0.040	4	½" or ¾"	20	0.9 + 0.070 x np
B10	287	117	243	72	9 + 2.4 x np	120	0.032	0.060	12	1"	20	1.5 + 0.126 x np
B12	287	117	234	63	9 + 2.4 x np	120	0.027	0.060	22	1¼"	27	1.7 + 0.116 x np
B15	465	72	432	40	9 + 2.3 x np	60	0.036	0.061	4	½" or ¾"	20	1.3 + 0.106 x np
B25	524	117	479	72	9 + 2.4 x np	120	0.063	0.111	12	1"	20	2.5 + 0.234 x np
B27	526	119	470	63	9 + 2.4 x np	140	0.060	0.111	22	1½"	27	2.7 + 0.226 x np
B35	392	241	324	174	11 + 2.4 x np	250	0.093	0.175	35	1½"	27	4.2 + 0.336 x np
B45	524	241	456	174	11 + 2.4 x np	250	0.128	0.234	35	1½"	27	5.5 + 0.427 x np
B50	524	241	441	159	13 + 2.4 x np	280	0.112	0.236	70	2½"	54	13 + 0.424 x np
B57	693	243	598	148	17 + 2.5 x np	280	0.165	0.330	78	2½"	54	16 + 0.565 x np
B60	374	364	*	*	16 + 2.14 x np	300	0.115	0.220	78	2" or 2½"	54	13 + 0.47 x np
B65	864	362	731	231	17 + 2.32 x np	300	0.270	0.590	200	# DN100	54	57.5 + 1.08 x np

np = Number of Plates

= Equipped With Flanges DN65 or DN100

* - See Special Drawings

Please note all information shown within this leaflet is subject to change without prior notice.

© GMS Thermal Products 2004
 Issue 1, January 2004