

GMS

Thermal Products Ltd

www.gmsthermal.co.uk



PACKAGED HEAT EXCHANGERS THERMAFLOW & THERMAPAK

GMS THERMAFLOW UNITS

ThermaFlow packaged plate heat exchanger DHWS units

- **Compact**
- **Flexible**
- **Low maintenance**
- **Instantaneous domestic hot water**

ThermaFlow packaged plate heat exchangers provide temperature controlled, instantaneous domestic hot water (DHW). Complete with plate heat exchanger, control panel, temperature control valve and primary pump, each ThermaFlow unit needs only to be connected to suitable supplies of electricity, primary hot water (eg a central heating boiler) and the domestic water system to provide all the instantaneous hot water you require.

On most systems the existing central heating boiler(s) will be able to meet the demand imposed by the ThermaFlow unit. If DHW demand is temporarily higher than the available boiler power then a ThermaFlow unit, combined with a small storage vessel to form a 'ThermaPak' semi-instantaneous unit (see pages 8 & 9), can provide the ideal solution. Our experienced sales and technical team can advise on the applicability of either system.



Special 3-Port designs as above are also available

Heat Exchanger

Each ThermaFlow unit has a 'ThermaFlex' gasketed plate heat exchanger. Plates and DHW connections are AISI 316 stainless steel, gaskets are NBR or EPDM(S). Each heat exchanger is designed and built for the duty specified. The heat exchanger plates cause high levels of turbulence and heat transfer, minimising scaling. The heat exchanger is easily dismantled and re-assembled for maintenance and, if demand increases at a later date, more plates can be added to increase the output.

Pumps

A built-in pump takes primary water to/from the system "low-loss" header and circulates it around the plate heat exchanger. This pump should not be used as the main boiler circulation pump. Duplex primary pumps are available as an option. (If the unit is to be connected to a primary system which generates a differential pressure higher than 10 kPa across the connections this should be reduced to 10 kPa or less - eg by using close-coupled primary connections.

Controls

The standard control panel incorporates a digital temperature display and controller, pump contactor(s) and overload(s), power on, pump run, pump trip and high temperature lights, high temperature cut-out (manual reset at the thermostat), Hi Temp. & Pump Trip volt-free contacts, relay for switching unit on/off remotely, Local/Remote/Stand-by selector switch and door interlock isolator.

ThermaFlow units re-start automatically when power is restored after a power cut. For the duplex primary pump option the panel also provides:-

- Pump 1 / Pump 2 / Auto selector switch.
- Auto-change-over on pump trip and with each remote start-up (when 'Auto' selected).

A modulating 4-port control valve regulates the primary heat input. Secondary water outlet temperature is measured accurately by thermo-sensor. An independent 'High Limit' thermostat protects against high temperature fault conditions by shutting down the primary pump. It also overrides the controller and closes the 4-port valve.

WATER HEATING MADE EASY

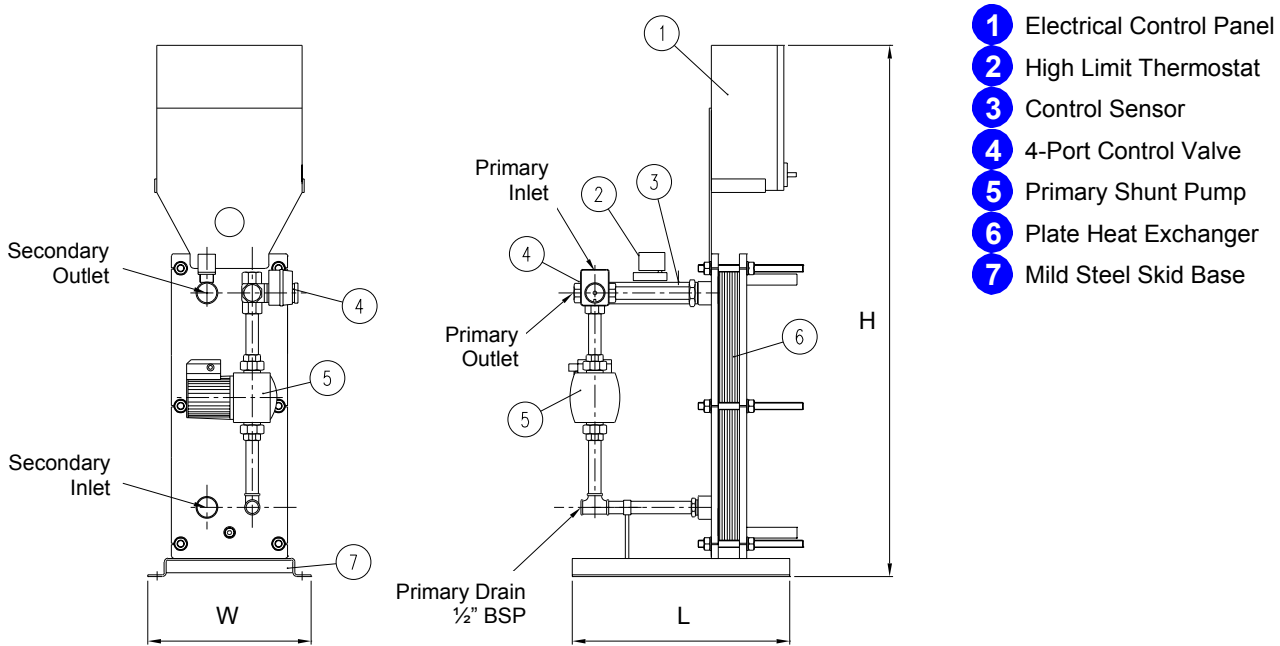

Unit Size	Output kW	DHW output * (L/Min)	DHW Connections BSP/PN16	Primary Connections BSP/PN6	Dry Weight kg	Dimensions (mm)		
						L	W	H
TF35	35	9	1" BSP	1" BSP	87	600	450	1445
TF60	60	16	1" BSP	1" BSP	87	600	450	1445
TF90	90	23	1" BSP	1" BSP	87	600	450	1445
TF120	120	31	1" BSP	1" BSP	87	600	450	1445
TF140	140	37	1" BSP	1" BSP	87	600	450	1445
TF175	175	46	1" BSP	1" BSP	120	600	450	1445
TF210	210	55	1" BSP	1¼" BSP	120	600	450	1445
TF265	265	69	1¼" BSP	1¼" BSP	120	600	450	1445
TF320	320	84	1¼" BSP	1½" BSP	120	600	450	1445
TF365	365	95	1½" BSP	1½" BSP	260	800	625	1530
TF420	420	110	1½" BSP	1½" BSP	260	800	625	1530
TF475	475	124	1½" BSP	1½" BSP	260	800	625	1530
TF530	530	138	1½" BSP	DN50	260	800	625	1530
TF600	600	157	2" BSP	DN50	260	800	625	1530
TF700	700	183	2" BSP	DN50	260	800	625	1530
TF800	800	209	2" BSP	DN50	260	800	625	1530
TF900	900	235	DN65	DN50	480	1320	940	1765
TF1000	1000	261	DN65	DN50	480	1320	940	1765
TF1200	1200	313	DN65	DN65	480	1320	940	1765
TF1400	1400	365	DN65	DN65	480	1320	940	1765
TF1600	1600	418	DN65	DN80	480	1320	940	1765
TF1800	1800	470	DN65	DN80	480	1320	940	1765

* - Flow rates based on 10-65°C

GMS THERMAPAK UNITS

ThermaPak packaged plate heat exchanger & buffer vessel units

- **Compact**
- **Flexible**
- **Low maintenance**
- **Semi-Instantaneous domestic hot water**
- **Extra water for peak periods reducing need for extra boiler power**

ThermaPak packages provide all the instantaneous hot water you require standard using a ThermaFlow package (see pages 4 & 5) and has an additional supply of water using a buffer vessel. The buffer vessel is 'charged' during period of low demand and used when a peak flow is required. The buffer vessels are sized depending on the application and type of building they are being installed in.



Typical ThermaPak package, installed in an unvented system

GMS manufacture buffer vessels using the following standard materials:

- Solid Copper
- Copper-Lined Steel
- Galvanised Steel
- Stainless Steel
- Glass/Polymer Lined Steel

WATER HEATING MADE EASY

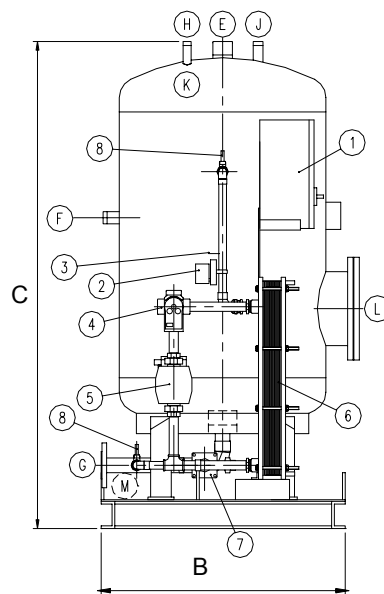
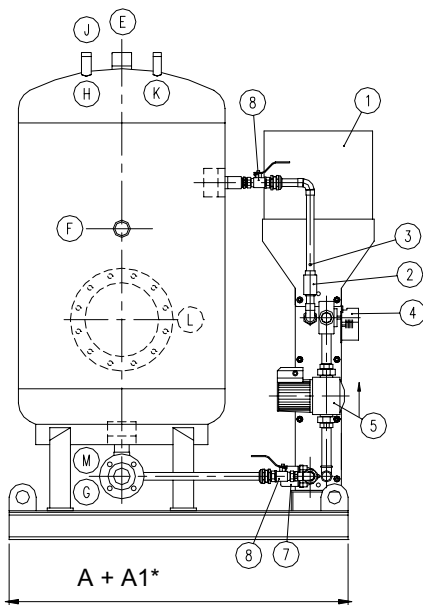

- 1 Electrical Control Panel
- 2 High Limit Thermostat
- 3 Control Sensor
- 4 4-Port Control Valve
- 5 Primary Shunt Pump
- 6 Plate Heat Exchanger
- 7 Secondary Shunt Pump
- 8 Isolating Valves

* - Dimension 'A1' - refer to page 3 for ThermaFlow unit dimension 'W'

Connections:

- E Secondary Flow
- F Secondary Return
- G Cold Feed
- H Pressure Gauge
- J Safety Valve (Size To Suit Application)
- K Thermometer
- L Inspection Opening
- M Secondary Drain

For primary connection sizes, refer to page 7 for ThermaFlow unit details

Vessel Size	Dimensions			Connection Sizes Screwed BSP/Flanged PN16						
	A *	B	C	E	F	G	H	K	L mm	M
200	800	800	1650	2" BSP	1" BSP	DN50	3/8" BSP	1/2" BSP	200	3/4" BSP
250	800	800	1950	2" BSP	1" BSP	DN50	3/8" BSP	1/2" BSP	200	3/4" BSP
300	900	900	1600	2" BSP	1" BSP	DN50	3/8" BSP	1/2" BSP	250	3/4" BSP
350	900	900	1850	2" BSP	1" BSP	DN50	3/8" BSP	1/2" BSP	250	3/4" BSP
400	900	900	2050	2" BSP	1" BSP	DN50	3/8" BSP	1/2" BSP	250	3/4" BSP
500	1000	1000	1925	2" BSP	1" BSP	DN50	3/8" BSP	1/2" BSP	300	3/4" BSP
600	1060	1060	1900	2" BSP	1" BSP	DN50	3/8" BSP	1/2" BSP	300	1" BSP
700	1060	1060	2130	2" BSP	1" BSP	DN50	3/8" BSP	1/2" BSP	300	1" BSP
800	1060	1060	2380	2" BSP	1" BSP	DN50	3/8" BSP	1/2" BSP	300	1" BSP
900	1100	1100	2400	2" BSP	1" BSP	DN50	3/8" BSP	1/2" BSP	300	1" BSP
1000	1200	1200	2200	DN65	1 1/2" BSP	DN65	3/8" BSP	1/2" BSP	300	1" BSP
1200	1200	1200	2535	DN65	1 1/2" BSP	DN65	3/8" BSP	1/2" BSP	300	1" BSP
1500	1350	1350	2400	DN65	1 1/2" BSP	DN65	3/8" BSP	1/2" BSP	380	1" BSP
2000	1350	1350	2850	DN80	1 1/2" BSP	DN80	3/8" BSP	1/2" BSP	380	1 1/2" BSP
2500	1525	1525	2850	DN80	1 1/2" BSP	DN80	3/8" BSP	1/2" BSP	450	1 1/2" BSP
3000	1525	1525	3300	DN100	2" BSP	DN100	3/8" BSP	1/2" BSP	450	1 1/2" BSP
3500	1670	1670	3200	DN100	2" BSP	DN100	3/8" BSP	1/2" BSP	450	1 1/2" BSP
4000	1670	1670	3550	DN100	2" BSP	DN100	3/8" BSP	1/2" BSP	450	1 1/2" BSP
4500	1825	1825	3200	DN100	2" BSP	DN100	3/8" BSP	1/2" BSP	450	1 1/2" BSP
5000	1825	1825	3500	DN100	2" BSP	DN100	3/8" BSP	1/2" BSP	450	1 1/2" BSP

Please note all information shown within this leaflet is subject to change without prior notice.